

# G27QS | Canopy Set

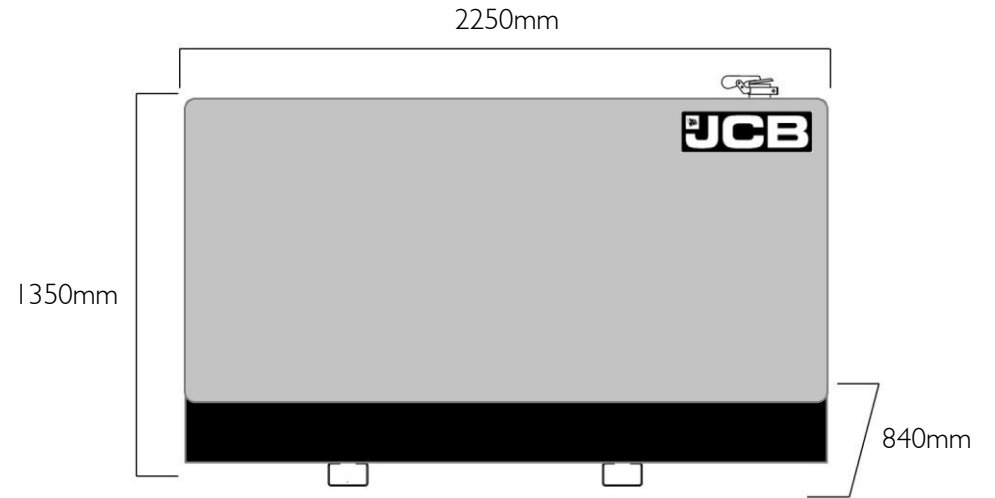

**DIESEL GENERATOR**

**STAGE IIIA**

## ELECTRICAL

Frequency (Hz)	Phases	Voltage (V)	Prime		Standby		MCB Rating (A)	Minimum ATP Rating (A)	Rated Speed (RPM)
			kVA	kW	kVA	kW			
50	3	400/230V	24.5	19.6	27.0	21.6	40	40	1500

## POWER FACTOR

3 Phase	0.8
1 Phase	1

## MAXIMUM LOAD IMPACT\*

kVA	24.50
kW	19.60

\*With 20% voltage and 10% frequency deviation @ 50Hz, 400V

## ALL RATINGS ARE TO STANDARD REFERENCE CONDITIONS ISO 8528

**Prime:** This rating is for the supply of continuous electrical power, at variable load, in lieu of commercially purchase power. There is no limitation on the annual hours of operation and 10% over load power can be supplied for 1 hour in 12.

**Standby:** This rating is for the supply of continuous electrical power, at variable load, in the event of a utility power failure. No overload is permitted.

**Stage IIIa** models are only emissions compliant at 50Hz Prime Power in accordance with 97-68EC.

### CANOPY/SKID

Lockable Maintenance Access Doors	●
Control Panel Viewing Window	●
Fork Pockets	Δ
Single Lift Point	Δ
Bunding	Δ
Open Frame	Δ
High Density Fire Retardant Foam	●
Yellow Paint	●
White Paint	Δ
Standard: ●    Not Available: x    Optional: Δ	

### ALTERNATOR ECP28 VL/4

Poles	4
Winding Connections	Star
Insulation	Class H
Enclosure	IP23
Exciter System	Self-regulating brushless
Voltage Regulator	AVR
Steady State Voltage Regulation	+/- 1.0%
Bearing	Single bearing sealed
Coupling	Flexible disc
Cooling	Direct drive centrifugal blower fan
Coating	Winding Protection Grey

### STARTING SYSTEM

Starter Motor	kW	2.00
Battery Capacity	Ah	110
Number of Batteries		1
Auxiliary Voltage	V	12

### ENGINE

<b>1500 RPM</b>		
Output Rating (PRP)	kW	23.00
Output Rating (Standby)	kW	25.00
Manufacturer and Model		Kohler/JCB KDI 2504 M
Fuel		Diesel
Injection		Direct
Aspiration		Naturally Aspirated
Cylinders		4
Bore and Stroke	mm	88 x 102
Displacement	L	2.482
Cooling		Water
Engine Oil Specification		API CH4-SAE 10W40
Compression Ratio		11.5 : 1
Engine Oil Capacity	L	11.30
Coolant Capacity	L	7.60
Governor		Mechanical
Air Filter		Single paper element
Engine Oil Consumption	100% Load	0.1% of fuel consumed

### FUEL SYSTEM

Diesel Specification		EN590
Standard Fuel Tank Capacity	L	81

# G27QS | Canopy Set



**GENERATORS  
IRELAND**

## FUEL CONSUMPTION

100% Load Prime	L/h	50Hz	6.60
75% Load Prime	L/h		5.30
50% Load Prime	L/h		4.05
100% Load Standby	L/h		7.25

## EXHAUST SYSTEM

Maximum Temperature 100% Standby	°C	50Hz	540.00
Exhaust Gas Flow 100% Standby	m <sup>3</sup> /min		2.71
Maximum Allowed Back Pressure	mbar		65.00
Exhaust Flange Size	mm	51.5	

## AIR SYSTEM

Intake Air Flow 100% Standby	m <sup>3</sup> /h	50Hz	92.00
Total Cooling Air Flow 100% Standby	m <sup>3</sup> /s		0.29
Alternator Fan Airflow	m <sup>3</sup> /s		0.09

## SOUND PRESSURE (CANOPY ONLY)

LpA (7m)	50Hz	dB(A)	64
----------	------	-------	----

## MECHANICAL FEATURES

Cooling Pack	●
Air Filter	●
Mechanical Governor	●
Low Oil Pressure Switch	●
Coolant Temperature Sender	●
Oil Temperature Sender	●
Radiator Guards	●
Hot Component Guards	Δ
Manual Oil Drain Pump (Canopy)	Δ
Water Jacket Heater	Δ
Pre-Filter with Separator	●
Fuel Level Sender	●
Internal Fuel Fill (Belly Tank)	●
3 Way Fuel Valve	Δ
Residential Silencer	●
Industrial Silencer	x

Standard: ●      Not Available: x      Optional: Δ

## ELECTRICAL FEATURES

AVR DSR	●
AVR DER	x
Winding Protection Standard	x
Winding Protection Standard +	x
Winding Protection Grey	●
Winding Protection Total	Δ
Winding Protection Total +	Δ
MAUX	●
PMG	Δ
Anti-Condensation Heater	Δ
3 Pole Moulded Case Circuit Breaker	●
4 Pole Moulded Case Circuit Breaker	Δ
Earth Leakage Protection (Shunt Trip)	Δ
Preparation for Earth Spike	●
Optional Voltages	Δ
Remote Screen	Δ
Emergency Stop Button	●
External Emergency Stop Button	●
Standard: ● Not Available: x Optional: Δ	

## BATTERY FEATURES

Battery Isolator	Δ
Battery Type	Lead Acid
Battery Size (Ah)	110
Number of Batteries	1
Battery Charger	Δ
Standard: ● Not Available: x Optional: Δ	

## JCB COMMUNICATION AND CONTROL

4510	x
4520	●
Standard: ● Not Available: x Optional: Δ	

## WEIGHT AND DIMENSIONS

Length	mm	2250
Width	mm	840
Height	mm	1350
Shipping Volume (sea ready)	m <sup>3</sup>	2.55
Weight*	Kg	1000.00

\*Standard build with all fluids except fuel

## CE PACK (OPTIONAL)

EMC Certification	●
Hot Guards	●
Belt Guards	●
Earth Leakage Relay	●
Sound Power Decal	●
EU Declaration for Engine Emissions	●
Complete Machine Declaration of Conformity	●
Standard: ● Not Available: x Optional: Δ	

## REFERENCE STANDARDS

JCB Generators are CE certified and conform to the following Directives (subject to a country requiring such standard):

- EN 12100, EN 13857, EN60204
- 2006/42/CE Machinery safety
- 2006/95/EC Low voltage
- 2004/108/CE Electromagnetic compatibility
- 2000/14/EC Sound Power Level (amended by 2005/88/EC)
- 97/68/EC Emissions(amended by 2002/88/EC & 2004/26/EC)
- Power according to ISO 8528 and ISO 3046
- Ambient reference conditions 1000mbar, 25°C, 30% relative humidity ISO3046

Information based on standard specification equipment unless otherwise stated.